

FLUKE®

Biomedical

AAPM Report No. 31

Standardized Methods For Measuring Diagnostic X-Ray Exposures

Report

March 2005
Manual No. AAPM-31-1 Rev. 2
©2004, 2005 Fluke Corporation, All rights reserved. Printed in U.S.A.
All product names are trademarks of their respective companies

**Fluke Biomedical
Radiation Management Services**

6045 Cochran Road
Cleveland, Ohio 44139
440.498.2564

www.flukebiomedical.com/rms

Report of Task Group 8

Diagnostic X-Ray Imaging Committee

Members

Robert Y.L. Chu (Chair)

Jane Fisher (Co-Chair)

Benjamin R. Archer

Burton J. Conway

Mitchell M. Goodsitt

Sharon Glaze

Joel E. Gray

Keith J. Strauss

July 1990

Published for the Physicists in Medicine by the American Institute of Physics

Additional copies of the report may be obtained from:

American Institute of Physics
C/O AIDC
64 Depot Road
Colchester, Vermont 05446
800.445.6638

DISCLAIMER: This publication is based on sources and information believed to be reliable, but the AAPM and the editors disclaim any warranty or liability based on or relating to the contents of this publication.

The AAPM does not endorse any products, manufacturers, or suppliers. Nothing in this publication should be interpreted as implying such endorsement.

Library of Congress Catalog Number: 90-56222

International Standard Book Number: 0-88318-874-0

International Standard Serial Number: 0271-7344

© 1991 by the American Association of Physicists in Medicine

All rights reserved. No part of this publication may be re-produced, stored in a retrieval system, or transmitted in any form or by any means (electronic, mechanical, photocopying, recording, or otherwise) without the prior written permission of the publisher.

Published by the American Institute of Physics, Inc. 335 East 45 Street, New York, NY 10017

Printed in the United States of America

(Blank page)

Table of Contents

Section 1:	General Information	1-1
1.1	Introduction	1-1
1.2	General Clarifications.....	1-1
Section 2:	Radiographic Entrance Skin Exposure	2-1
2.1	Introduction	2-1
2.2	Measurement Procedure	2-2
2.3	Patient Equivalent Phantom.....	2-3
2.4	Clarification	2-7
Section 3:	Mammography Exposure	3-1
3.1	Introduction	3-1
3.2	Measurement Procedure for Automatic Exposure Mode-(AEC)	3-1
3.3	Calculation of Average Glandular Dose	3-1
3.4	Mammography Phantoms.....	3-2
3.5	Clarification	3-3
Section 4:	Computed Tomography Dose Index (CTDI)	4-1
4.1	Introduction	4-1
4.2	Measurement Procedure	4-1
4.3	Computed Tomography Phantoms	4-2
4.4	Clarification	4-3
Section 5:	Conclusion	5-1
5.1	Conclusion	5-1
5.2	References	5-1
5.3	AAPM Report Series.....	5-2
5.4	Medical Physics Reprint.....	5-3

(Blank Page)

Section 1

General Information

1.1 Introduction

The task group on "Standardized Methods for Measuring Diagnostic X-ray Exposures" was formed by the Diagnostic X-ray Imaging Committee to provide a standardized method for radiologic physicists to use in complying with Section DR.2.2.10.2 of the JCAHO Standards. Section DR.2.2.10.2 reads as follows:

DR.2.2.10 Provisions that a qualified physician, qualified medical radiation physicist or other qualified individual.

DR.2.2.10.2 monitor doses from diagnostic radiology procedures.

It should be noted that, for compliance with this standard, radiographic exposure measurements must be room specific and should be determined for commonly used projections in each room¹.

The topics covered in this document include procedures for measuring patient exposure, suggested phantoms for use with automatic exposure control (AEC) systems, recommended common projections for which exposure data should be measured; references to national average exposure data for these common projections, and a reference bibliography. Measured patient exposures should be compared to national average values. Corrective action should be taken if high patient exposures or room-to-room discrepancies are noted.

1.2 General Clarifications

The procedures described in this document assume that processor and x-ray equipment quality control testing has already been performed and image quality optimized. It is also assumed that the radiologic physicist using this document is familiar with ionization chamber response characteristics (i.e. energy and rate dependence) and the optimal ion chamber of choice for use with the diagnostic x-ray equipment addressed in this document. Information regarding ionization chamber performance and quality control testing can be found in other AAPM Reports^{18,23} and other publications^{3,4,5,6,11,12,17,20}.

(Blank page)

Section 2

Radiographic Entrance Skin Exposure

2.1 Introduction

This section contains procedures for measuring entrance skin exposure (ESE) in both manual and automatic exposure control (AEC) radiographic systems. Entrance skin exposure should be measured for the common projections and the results evaluated with respect to the national average ESE data shown in Table 1.

Table 1
Entrance Skin Exposures (Free-In-Air)

Projection	Median ESE ^a (x10 ⁻⁶ C/kg)	
	Grid	Non-Grid
Chest (P/A) ^{15,b}	3.5 (2.5, 4.7)	1.7 (1.4, 2.4)
Skull (Lateral) ²⁶	39.2 ± 28.9 ^{c,d}	N/A
Abdomen (A/P) ^{15,e}	77.7 (56.8, 114.4)	N/A
LS Spine (A/P) ^{15,e}	85.9 (65.0, 125.6)	N/A
Extremity ²⁶	37.7 ± 37.9 ^{f,d}	N/A

^a Values in parenthesis are 1st and 3rd quartile values.

^b 300 speed system 1984 NEXT Hospital data.

^c Lateral skull combined grid and non-grid (pre-1984 NEXT data)

^d ± values are standard error of the mean, quartile values not available.

^e 400 speed system 1987 NEXT Hospital data only.

^f Foot (DP) combined grid and non-grid (pre-1984 NEXT data).

N/A Not available, none reported for abdomen and spine.

In addition, knowledge of the following parameters is needed to obtain the required ESE values and determine specific organ dose:

- a. Projection, view.
- b. Source -skin- distance (SSD).
- c. Source-image receptor distance (SID).
- d. Radiographic technique factors including field size and HVL for selected projection.
- e. Exposure, free-in-air, at a known distance.

The above-mentioned parameters must be tube specific and should be those used clinically for a selected projection. Patient thickness values and the tabletop-image receptor distance are needed to calculate the skin entrance location.

The thicknesses for an average patient (see Table 2) are a good choice since these values are used for the national average ESE data shown in Table 1. More complete ESE data for various speed systems are available in Reference 16.

Table 2
Exam/Projection Descriptions and Anthropometric Guidelines

Description	Thickness of Part	
	Inches	Centimeters
Chest (P/A)	9	23
Skull (Lateral)	6	15
Abdomen (A/P) (KUB)	9	23
Lumbo-Sacral Spine (A/P)	9	23
Extremity (Foot)	3	8

2.2 Measurement Procedure

A. Manual Mode

1. Set the clinically used SID. Center the ion chamber, in the x-ray field at a fixed distance from the focal spot and approximately 23 cm above the table top to minimize backscatter. Measure and record the distance from the focal spot to the center of the ion chamber. The above geometry should be modified as necessary for below table units.
2. Reduce the x-ray field area so that it is slightly larger than the ion chamber.
3. Set the x-ray generator at the desired technique factors.
4. Record the average free-in-air exposure.
5. Repeat step 4 for other common technique factors.
6. From the free-in-air exposure values obtained in steps (4) and (5), calculate the ESE for the selected projection using the inverse square correction for the ion chamber to skin entrance position and the parameters listed in Section 2.1

B. Automatic Exposure Control Mode (AEC)

1. Select the clinically used SID and density setting.
2. Position an appropriate patient-equivalent phantom (see Section 2-3) in the x-ray field between the focal spot and the AEC detectors. Adjust the x-ray field size so that it is large enough to cover the selected AEC detectors.
3. Position the ion chamber within the x-ray field between the focal spot and the phantom. The ion chamber should be approximately 23 cm above the phantom surface to reduce backscatter and positioned outside the AEC detector's sensory area. To minimize the influence of the heel effect, the ion chamber should be placed as close to the central axis as possible. Measure and record the distance from the focal spot to the center of the ion chamber.
4. Set the x-ray generator at the desired projection specific technique factors and insert a loaded cassette into the bucky tray.
5. Make an exposure and record the ion chamber reading.
6. Repeat steps 1 through 5 for other phantoms and projection specific technique factors.
7. Using the measured free-in-air exposure values, calculate the ESE for each of the selected projection by using inverse square corrections for the ion chamber to skin entrance position.

C. Fluoroscopic Automatic Brightness Mode (ABS)

1. Set the clinically used SID and field of view. Center the ion chamber in the fluoroscopic x-ray field at the skin entrance position. For undertable x-ray tubes, the skin entrance position is at the tabletop. For overtable x-ray tubes, measure at the skin entrance position above the tabletop.
2. Position a patient equivalent phantom (Section 2-3) in the fluoroscopic x-ray field between the ion chamber and the image intensifier.
3. Measure and record the skin entrance exposure rate for clinically used kVp values and field of view sizes on the image intensifier. The machine indicated kVp and mA for each measured ESE rate should be recorded.

2.3 Patient Equivalent Phantoms

For radiographic AEC or fluoroscopic ABS operational modes, use of attenuating material (phantoms) between the focal spot and AEC or ABS detectors necessary. As these detectors are energy dependent, measurement of skin entrance exposures requires the use of patient-equivalent phantoms for meaningful results.

Commercially available anthropomorphic phantoms may not be patient equivalent in the diagnostic energy range. Acrylic and aluminum phantoms have been developed by the American National Standards Institute (ANSI)²⁸ and the Center for Devices and Radiological Health (CDRH)^{13,14,15}. The AAPM has conducted comparison testing of a modified ANSI phantom and the CDRH phantoms. Results of this comparative testing are given in Table 3. It should be noted, that the patient equivalency of the CDRH phantoms has been established clinically. National skin entrance exposure data which can be used for comparative purposes exists for the CDRH phantoms and are given in Table 1. Descriptions of the modified ANSI and CDRH phantoms which can be used for diagnostic projections follow:

- a. CDRH Chest: The chest phantom consists of 25.4 x 25.4 cm pieces of type 1100 alloy aluminum and clear acrylic with a 19 cm air gap. The exact configuration of aluminum, acrylic and air gap is detailed in Figure 2-1. Clinical testing of the phantom has shown it to be equivalent to a 23 cm patient for the PA Chest projection¹⁴.

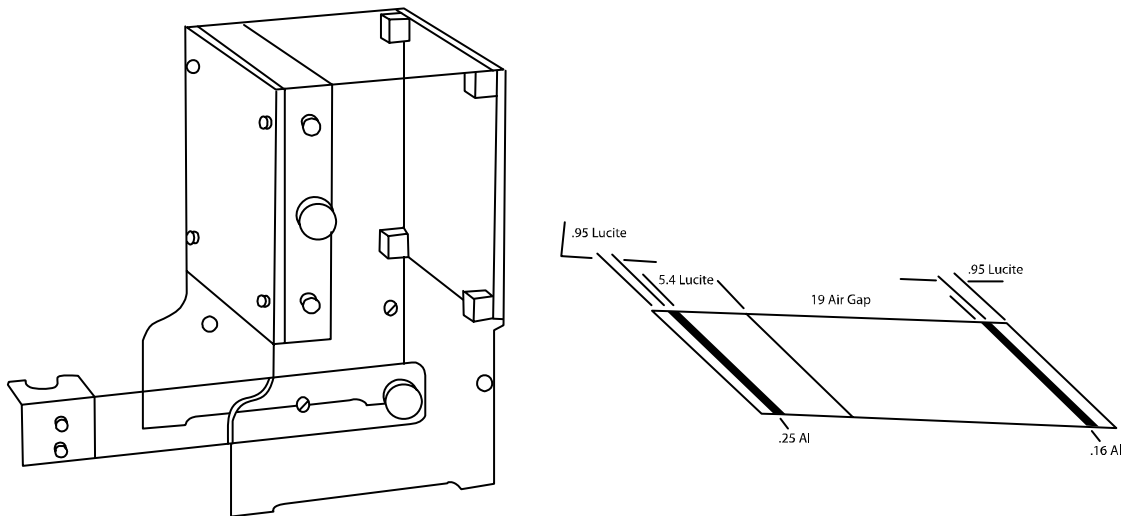

Figure 2-1. CDRH Patient Equivalent and Aluminum (LucAl Standard Chest Phantom (All dimensions in cm)

- b. ANSI Chest: The chest phantom consists of 30.5 x 30.5 x 2.54 cm pieces of clear acrylic, 3 mm of type 1100 alloy aluminum, and a 5.08 cm air gap. The exact configuration is detailed in Figure 2-1. Comparison testing found the ESE obtained with the ANSI phantom to be 33% higher than with the CDRH chest phantom (Table 3)

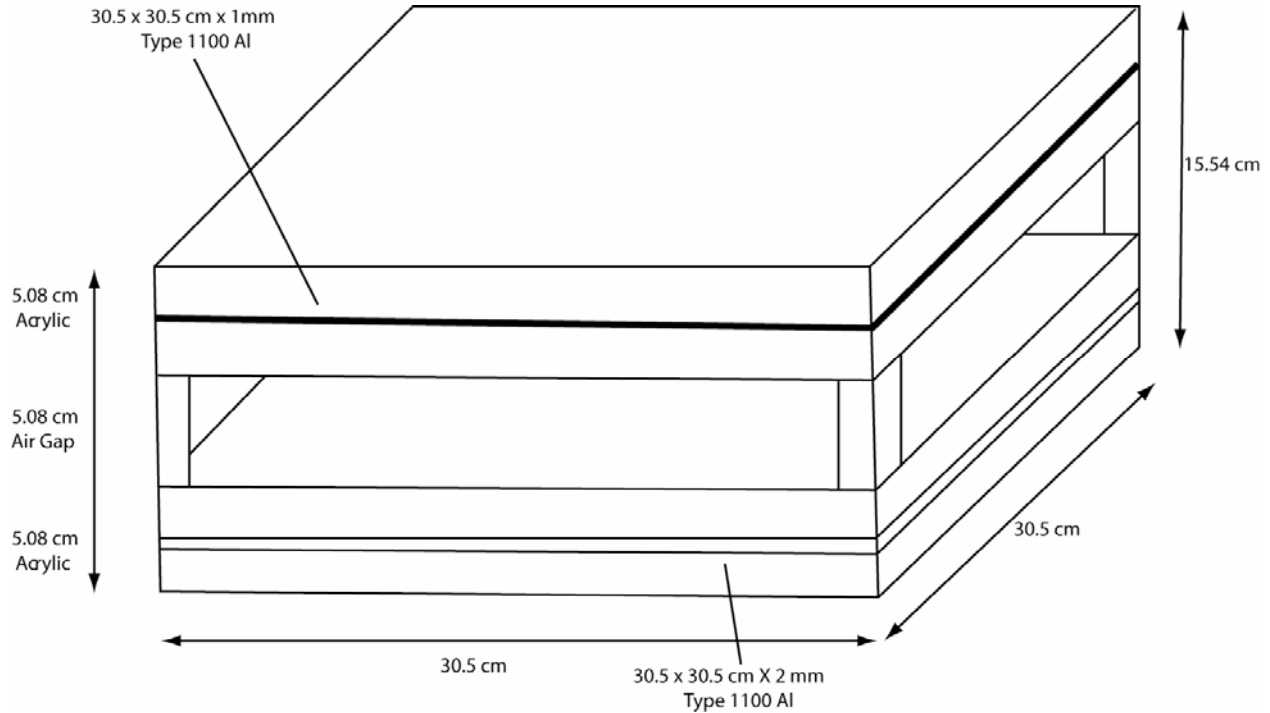

Figure 2-2. ANSI Sensitometry Chest Phantom

Table 3
CDRH-ANSI Phantom Comparison and Prototype Dosimetry Study ^a

Projection	Entrance Exposure ($\times 10^{-6}$ C/kg)	
	CDRH Phantom ^b	ANSI Phantom ^b
PA Chest	6.19 \pm 2.84	8.26 \pm 4.13
AP Abdomen	98.81 \pm 48.5	87.72 \pm 31.73
AP LS Spine	110.42 \pm 54.7	96.23 \pm 41.02
Lateral Skull	N/A	54.44 \pm 20.90
Extremity	N/A	5.42 \pm 4.64

N/A no phantom available.

^aThese results are from a survey conducted in 9 institutions.

^b \pm values are standard error of mean.

- c. CDRH Abdomen/Lumbar Spine: The abdomen and lumbar spine phantom consists of 25.4 x 25.4 cm pieces of clear acrylic 16.95 cm thick in the soft tissue region and 0.46 cm of aluminum (type 1100 alloy) and 18.95 cm acrylic for the spinal region. The exact configuration of aluminum and acrylic is detailed in Figure 2-3. Clinical testing of the phantom has shown it to be equivalent to a 21 cm patient for the AP abdomen and lumbar spine projections¹⁵.

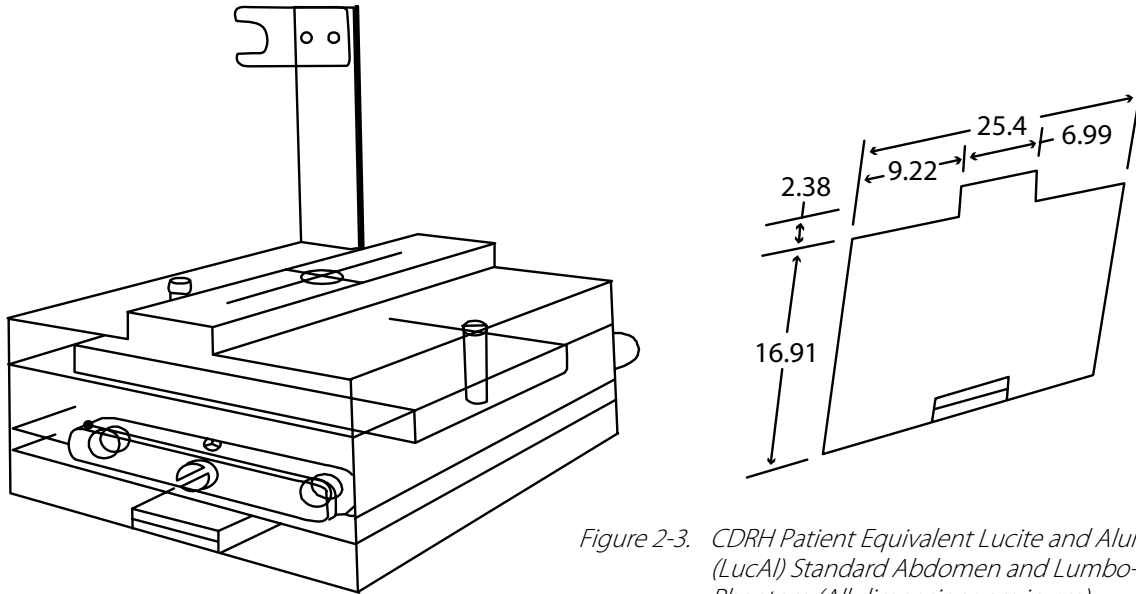

Figure 2-3. CDRH Patient Equivalent Lucite and Aluminum (LucAl) Standard Abdomen and Lumbo-Sacral Spine Phantom (All dimensions are in cm)

- d. Modified ANSI Abdomen/Lumbar Spine: The abdomen and lumbar spine phantom consists of 30.5 x 30.5 cm pieces of clear acrylic 17.78 cm thick. The phantom has been modified to include a 7 x 30.5 cm piece of aluminum (type 1100 alloy) 4.5 mm thick in order to provide additional attenuation in the spinal region. The exact configuration of aluminum and acrylic is shown in Figure 2-4. Comparison testing found the modified ANSI phantom ESE results to be 15% lower than the CDRH abdomen and lumbar spine phantom results (Table 3).

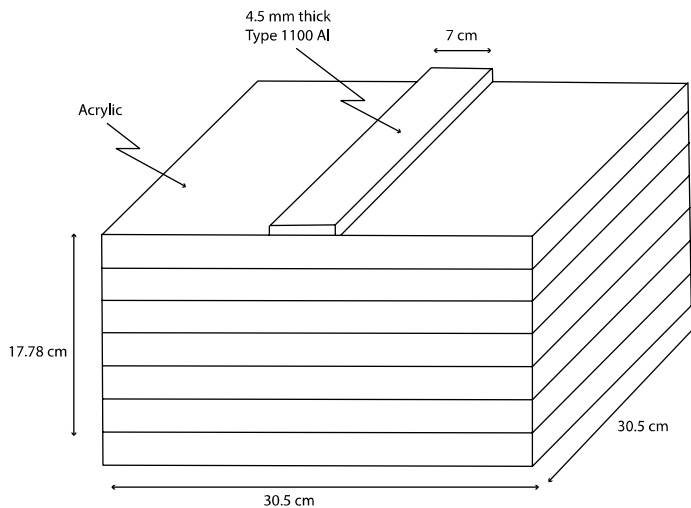

Figure 2-4. Modified ANSI Sensitometry Abdomen and Lumbo-Sacral Spine Phantom

NOTE: Addition of 4.5 mm Thick Type 1100 Al for Spine

- e. ANSI Skull: The skull phantom has the same configuration as the chest phantom, consisting of four 30.5 x 30.5 x 2.54 cm pieces of clear acrylic, 3 mm of aluminum (type 1100 alloy), and a 5.08 cm piece of acrylic as shown in Figure 2-5. The patient equivalency of this phantom has not been established at this time.

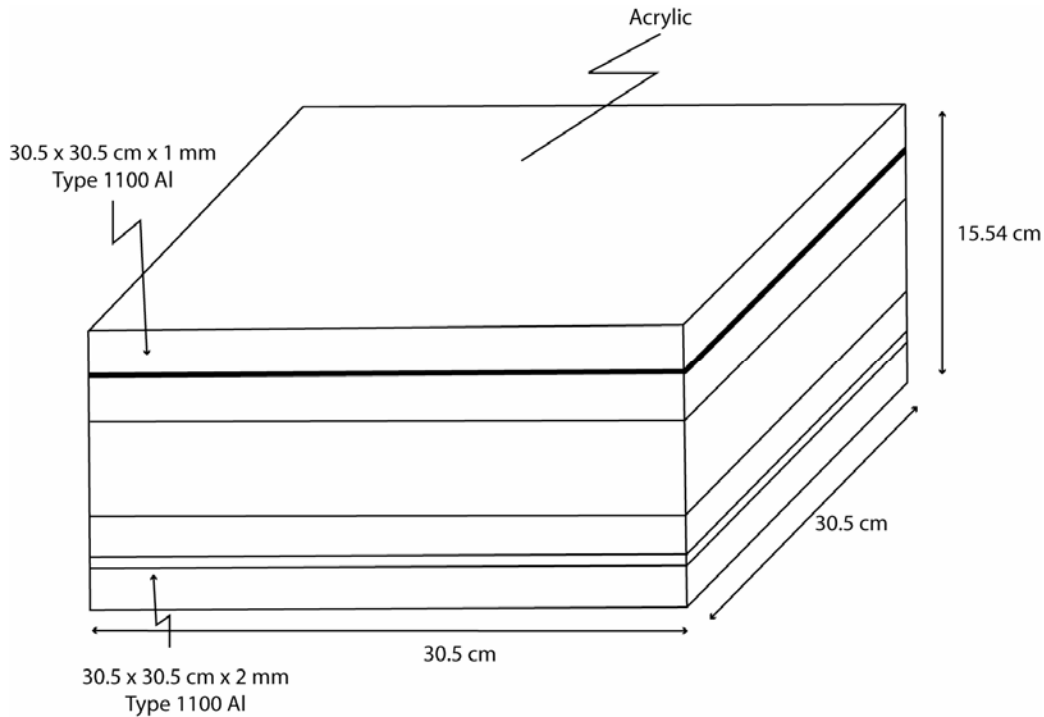

Figure 2-5. ANSI Sensitometry Skull Phantom

- f. ANSI Extremity: The extremity phantom consists of a 30.5 x 30.5 cm x 2 mm thick piece of aluminum (type 1100 alloy) sandwiched between two 30.5 x 30.5 x 2.54 cm thick pieces of clear acrylic. The exact configuration of aluminum and acrylic is shown in Figure 2-6. The patient equivalency of this phantom has not been established at this time.

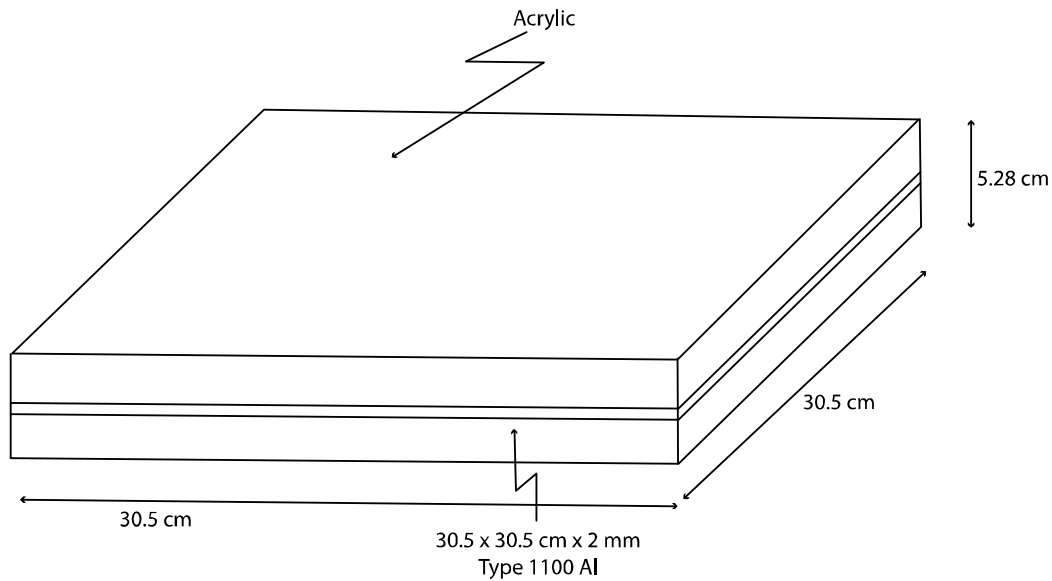

Figure 2-6. ANSI Sensitometry Extremity Phantom.

2.4 Clarification

- a. The following precautions should be followed in using any of the above phantoms to determine ESE values:
 1. The phantom must cover the active area of the AEC detectors.
 2. The ion chamber must not mask the active area of the AEC detectors.
 3. The sensitive volume of the probe should be placed so as to minimize backscatter whenever possible. This can generally be accomplished by placing the probe approximately 23 cm or more from the phantom.
- b. The ANSI phantom size (length X width) can be reduced to 25 x 25 cm without affecting the ESE results.

(Blank page)

Section 3

Mammography Exposure

3.1 Introduction

This section presents a protocol for measurement of mammography dose and recommendations for mammography phantoms. Since glandular tissue in the breast is the primary tissue at risk for carcinogenesis, average glandular dose is the value of interest when discussing mammography. Average glandular dose has also been adopted for use by the ACR in its Mammography Accreditation Program.

Calculation of the average glandular dose requires knowledge of the entrance skin exposure free-in-air for a given compressed breast thickness and the x-ray beam half value layer (HVL)². If the HVL is not known from quality control data, procedures for determining HVL can be found in other AAPM publications^{18,23,27}.

3.2 Measurement Procedure for Automatic Exposure Mode (AEC)

- a. Position a patient-equivalent breast phantom on the image receptor so that the phantom covers the AEC detectors. Make sure that a loaded cassette is in the image receptor holder and that the compression device is clinically positioned. If a grid is used clinically, it should be in place.
- b. Place the ion chamber 4.5 cm above the image receptor holder and approximately 1 cm from the chest wall edge of the image receptor and adjacent to the right side of the phantom. Make an exposure at the clinically used kVp and record the free-in-air exposure.

The ion-chamber is placed to one-side of the phantom in order to minimize backscatter from the phantom and to avoid masking the AEC detector. Since this measurement is necessarily not made on the central axis, care should be taken to verify that no large exposure exists between the measurement position and the central axis.

3.3 Calculation of Average Glandular Dose

Using the measured free-in-air exposure, calculate the average glandular dose for a 50% adipose, 50% glandular 4.5 cm compressed breast using the following equation:

$$D_g = D_{gN} X_a$$

- D_g is the average glandular dose.
- D_{gN} is the average glandular dose resulting from an entrance exposure in air of 1 roentgen (Table 4 and Reference 7 and 9).
- X_a is the average free-in-air exposure needed to produce an optimally exposed image obtained in Section 3.2.

3.4 Mammography Phantoms

Mammographic phantoms with a variety of features are available commercially. The phantom used in the American College of Radiology Mammography Accreditation Program is a clear acrylic phantom²⁵ that is equivalent to a 4.2 cm compressed breast (50% adipose, 50% glandular) for film-screen mammography and a 4.7 cm compressed breast for xeromammography. National data for this phantom are given in Table 5.

Table 4. ^{8,9,10,11,12}
Firm Compressions-Uniform Breast Thickness
Craniocaudal View, Uniform Breast Thicknesses
Between 3 and 8 cm, 50 Percent (By Weight)
Glandular Tissue Content
Glandular Tissue Dose (mrad) For 1 R^a
Entrance Exposure (Free-In-Air)

HVL (mm Al)	Compressed Breast Thickness					
	3 cm	4 cm	5 cm	6 cm	7 cm	8 cm
0.3	220(220)*	185(175)*	150(140)*	125(115)*	100(95)*	
0.4		235(220)*	190(174)*	160(145)*		
0.6		325	275	235	205	180
0.8	470	395	335	295	260	230
1.0	535	455	395	350	310	275
1.2	595	515	450	400	360	325
1.4	645	570	510	460	415	375
1.6	710	630	565	515	470	425

* Values in parentheses are for molybdenum and molybdenum-tungsten alloy targets; all other values are for tungsten targets.

^a Divide table values by 25.8 to convert to tissue dose (mGy) for 1 mC/kg exposure.

Table 5
Mean Glandular Dose Per Image (Next88 Data)

Screen-Film Systems	n*	ACR Equivalent Phantom ^a Phantom ^b		n*	RMI Model 152C	
		Mean Dose(mGy)	Mean ESE (mC / kg)		Mean Dose (mGy)	Mean ESE (mC / kg)
All	183	1.32	0.175	158	1.59	0.148
Grid	156	1.42	0.187	136	1.68	0.196
Non-Grid	27	.079	0.105	22	1.03	0.095
Xeromammography						
All	39	4.02	0.219	33	4.32	0.217

*n = number of facilities

^a 3.83 cm equivalent acrylic phantom. Equivalent to a 4.2 cm compressed breast tissue (50% adipose 50% glandular) for screen-film mammography and 4.5 cm compressed breast tissue for xeromammography.

^b 4.34 cm equivalent acrylic phantom. Equivalent to a 4.7 cm compressed breast tissue (50% adipose 50% glandular) for screen-film mammography and 5.0 cm compressed breast for xeromammography.

3.5 Clarification

The following precautions should be followed:

- a. In using any of the above phantoms to determine ESE; the phantom must cover the active area of the AEC detectors. -
- b. The compression device must be in the beam and should be placed as close to the phantom as possible.
- c. The ion chamber must not mask the AEC detectors.
- d. A loaded cassette must in the unit when making any AEC measurements.

(Blank page)

Section 4

Computed Tomography Dose Index (CTDI)

4.1 Introduction

This section contains protocols for determining the CTDI associated with typical computed tomography (CT) examinations of the head and body. It is assumed that an ion chamber designed for CT measurements will be used with acrylic CT head and body dosimetry phantoms described in Section 4.3.

4.2 Measurement Procedure

- A After placing the head phantom on the head holder or the body phantom on the tabletop, position the phantom so that one of the surface dosimeter holes is located at the point of maximum exposure as described in the manufacturer's literature. Acrylic rods should be placed in all the dosimeter holes with at least four acrylic alignment rods placed in surface holes.
- B Using the light localizer or laser alignment lights align and center the dosimetry phantom axially and in the center of the x-ray slice width. Make sure that the phantom is level and aligned with the central axis of the scanner in all directions (minimal pitch and yaw). Alignment can be assessed by viewing a lateral scout view of the phantom.
- C Initiate one scan of the phantom using a typical clinical technique to check centering accuracy.
- D Place the cursor in the image of the center hole of the phantom and determine its location using the CT software. If the center hole of the phantom is within ± 5 mm of the center of the scan field, proceed with the following steps. If it is not within this tolerance, re-center the phantom.
- E Place the CT ion chamber in the center hole of the phantom. The center of the ion chamber should be in the center of the x-ray slice.
- F Select a typical clinical head or body technique and record the kVp, mA or mAs, filters (both tube filtration and beam shaping filter), scan diameter, nominal slice thickness, scan time, number of x-ray pulses and pulse length, or notation that the radiation is continuous.
- G Initiate a single CT scan and record the results.

Calculate CTDI:

$$X_c = X_r C_c f L/T$$

X_c Is the calculated CTDI.

X_r Is the electrometer reading obtained in this setup.

C_c is the calibration correction factor for the ion chamber and electrometer.

f is the conversion factor used to convert dose-in-air to absorbed dose in other attenuating materials (see Section 4.4).

L is the effective length of the ion chamber.

T is the nominal CT slice thickness.

- H. Relocate the ion chamber to the surface hole located at the point of maximum exposure (see Section 4.2, A) and repeat step (g) after making sure that an acrylic rod has been placed in the center hole.
- I. Repeat this procedure using appropriate phantoms for common clinical head and body techniques.

4.3. Computed Tomography Phantoms

There are currently two CT dosimetry phantoms in common use. The head phantom consists of a 16 cm diameter clear acrylic cylinder 15 cm in length. The body phantom consists of a 32 cm diameter clear acrylic cylinder 15 cm in length. Both phantoms have 8 surface dosimeter holes and one central dosimeter hole with removable acrylic rods or alignment rods. The exact configuration of the head phantom is shown in Figure 4.1. Both of these dosimetry phantoms are discussed in more detail in the Code of Federal Regulations, 21 CFR 1020.23, Section (b)(6). 4.4 Clarification.

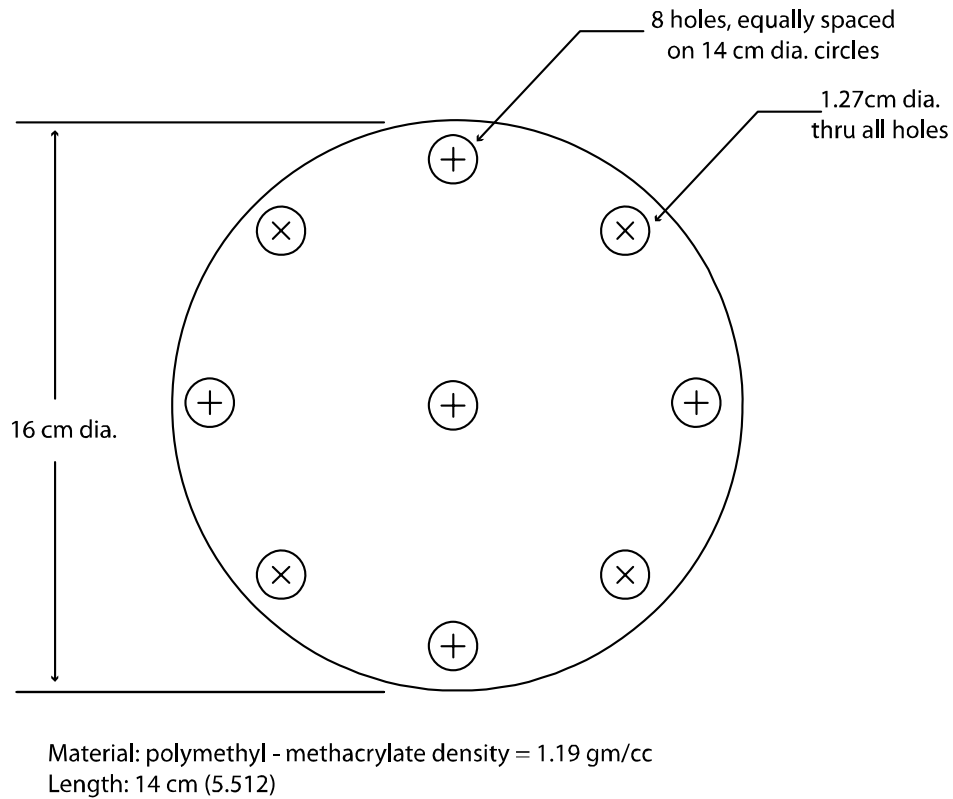

Figure 4-1. CT Head Phantom

4.4 Clarification

- a. There are two dose descriptors used in CT dosimetry namely, the computed tomography dose index (CTDI) and the multiple scan average dose (MSAD). Specification of CT dose in terms of CTDI was selected for this document as it is the dose descriptor specified in the Federal Performance Standard on Diagnostic X-ray Equipment. The Code of Federal Regulations, 21 CFR 1020.33, section (b)(1) defines CTDI as “the integral of the dose profile along a line perpendicular to the tomographic plane divided by the product of the nominal tomographic section thickness and the number of tomograms produced in a single scan.” While carefully defined, the CTDI is difficult to measure exactly in the field since it is a restricted subset of the more general MSAD. The CTDI is equivalent to the MSAD that results from a series of 14 scans spaced by the nominal section thickness. Because the active length of the ion chamber (L) is fixed, the estimate of the MSAD will represent varying numbers of contiguous scans, depending on nominal slice thickness (T). In fact, the MSAD would correspond to the average dose at the center of L/T contiguous scans²². For example, slice thicknesses of 10 mm and 8 mm will produce MSADs that represent the average doses at the center of a series of scans consisting of 10 and 12 scans respectively for a chamber with an active length of 10 cm. In this example, the MSAD would underestimate the CTDI by about 10 to 15 percent. When used to estimate the CTDI for small slice thicknesses, the ion chamber measurement can correspond to a very large number of contiguous scans. In the latter example, the resulting MSAD could overestimate the CTDI by as much as a factor of two.

As can be seen from the above discussion, the closeness of the estimate of the CTDI from the MSAD depends primarily on the slice thickness and the fixed length of the ion chamber. Since most conventional CT ion chambers are 10 cm long, a series of contiguous scans with a nominal thickness of 8 mm will meet this CTDI criteria. For simplicity, we have assumed that the conditions for measurement of CTDI are met. When these conditions cannot be met or if scans are not separated by the slice thickness, MSAD is the preferred dose descriptor^{21,22,23,24}.

- b. It should be noted that exposure in the surface holes will be significantly higher than the exposure on the surface due to the additional scatter from the overlying acrylic. However, the doses in the surface holes and the center hole are conventionally used for comparison purposes.
- c. The support material of the head holder or the patient table will reduce the exposures in adjacent surface holes.
- d. Dosimetry in which only a partial volume of the ion chamber is irradiated presents some significant difficulties. An ion chamber designed for general use has significant variations in sensitivity, when partially irradiated, over the entire volume. Chambers specifically designed for CT dose measurement have been described in the literature²¹ and are commercially available.
- e. An f factor is used to convert exposure in air to absorbed dose in tissue or other attenuating matter. The f factor for soft tissue is usually used in calculating absorbed dose for the selected effective photon energy. For muscle at 70 keV the f factor is 0.94 rad/roentgen. In CT, however, the manufacturers usually report the CT dose as the absorbed dose in acrylic, not soft tissue. At an effective energy of 70 keV the f factor is 0.78 rad/roentgen for acrylic. When calculating CTDI in Section 4.2-G, the f factor used should be specified.
- f. At least one manufacturer's design does not allow the identification of the point of maximum exposure on the surface of the phantom for scan rotations which are not 360°. This position depends on the tube location when the exposure button is depressed. If in doubt, perform several scans and average the results or limit measurements to the center hole of the phantom.

(Blank page)

Section 5 Conclusion

5.1 Conclusion

The goal of patient dose monitoring should be to identify those projections which give high patient exposures. Efforts should then be made to reduce these exposures. National average ESE data¹⁶ are available for guidance in evaluation of patient exposures. For those projections not included in the national ESE data, a room-to-room comparison within a given facility be used to locate high exposure projections.

High patient exposures may indicate a poorly integrated imaging system, outdated manual radiographic technique charts, film processing problems, or a problem with the x-ray equipment. Following identification of high exposure projections, causes should be identified and appropriate steps should be taken to reduce exposures without adversely affecting image quality.

5.2 References

1. An Analysis of the New JCAHO Standards for Diagnostic Radiology and Nuclear Medicine, AAPM, ACR and ACMP paper, 1989, available from AAPM New York
2. Hammerstein et. al., Absorbed Radiation Dose in Mammography, Radiology 130:485, 1979
3. Hanison R. M., Tissue-air Ratios and Scatter-air Ratios for Diagnostic Radiology (1-4 mm A1 HVL). Phys. Med. Biol., 28:1-18, 1983.
4. Harrison R. M., Backscatter Factors for Diagnostic Radiology (1-4 mm A1 HVL), Phys. Med. Biol. 27:1465-1474, 1982.
5. ICRP Publication 34, Protection of the Patient in Diagnostic Radiology. Committee 3 of the International Commission on Radiological Protection, Pergamon Press, May, 1982.
6. McGuire E. L, and Dickson P. A., Exposure and Organ Dose Estimation in Diagnostic Radiology. Med. Phys. 13:913-916, 1986.
7. NCRP Report No. 85: Mammography--A User's Guide. NCRP Publications, Bethesda, MD, Reprinted August 1987.
8. NBS Handbook 138: Medical Physics Data Book, U.S. Government Printing Office, Washington, D.C., March 1982.
9. Rosenstein, M., Andersen, L. W, and Warner, G. G., Handbook of Glandular Tissue Doses in Mammography. HHS Publ. FDA 85-8239, Reprinted May 1987.
10. Rosenstein, M. and Andersen L. W., Computer Program for Absorbed Dose to the Breast in Mammography. HHS Publ. FDA 85-8239, July 1985.
11. Rosenstein M, Handbook of Selected Tissue Doses for Projections Common in Diagnostic Radiology. HHS Publ. FDA 89-8031, December 1988.
12. Rosenstein M. and Kereiakes J. G., Handbook of Radiation Doses in Nuclear Medicine and Diagnostic X-ray. CRC Press Inc., 1980.
13. Arimille P. A., The Physics of Medical Imaging; Recording System Measurements and Techniques, AAPM Monograph No. 3, Edited by Haus, AIP, New York, 105ff, 1979.

14. Conway B. J. et. al. Beam Quality Independent Attenuation Phantom for Estimating Patient Exposure from X-ray Automatic Exposure Controlled Chest Examinations, *Med. Phys.* 11:827-832, 1984.
15. Conway B. J. et. al. A Patient Equivalent Phantom for Estimating Patient Exposure from Automatic Exposure Controlled X-ray Examinations of the Abdomen and Lumbo-Sacral Spine. *Med. Phys.* 17:448-453, 1990.
16. Nationwide Evaluation of X-ray Trends (NEXT), Tabulation and Graphical Summary of Survey 1984 through 1987. Conference of Radiation Control Program Directors, Inc., Frankfort, KY, CRCPD 89-3, 1989.
17. NCRP Report #99, Quality Assurance for Diagnostic Imaging Equipment. NCRP, Bethesda, MD 1988.
18. AAPM Report No. 25. Protocols for the Radiation Safety Surveys of Diagnostic Radiological Equipment. AAPM, 1989.
19. Code of Federal Regulations, 21 CFR 1020.23, Section (b)(6).
20. Suzuki A. S., Suzuki M.N., Use of a Pencil-shaped Ionization Chamber for Measurement of Exposure Resulting from a Computed Tomography Scan. *Med. Phys.* 5:536-539, 1978.
21. Jucius R. A., Kambic G. X., Measurements of Computed Tomography X-ray Fields Utilizing the Partial Volume Effect. *Med. Phys.* 7:379-382, 1980.
22. Shope T B., Gagne R. M., Johnson G. C, A Method for Describing the Doses Delivered by Transmission X-ray Computed Tomography. *Med. Phys.* 8:488-495, 1981.
23. AAPM Report No. 14, Performance Specifications and Acceptance Testing for X-ray Generators and Automatic Exposure Control Devices, AIP, 1:96, 1985.
24. McCrohan J.L., et. al., Average Radiation Doses in a Standard Head Examination for 250 CT Systems, *Radiology* 163:263-268, 1987.
25. Hendrick, R.E., Standardization of Image Quality and Radiation Dose in Mammography. *Radiology* 174:648-654, 1990.
26. Nationwide Evaluation of X-ray Trends...Eight Years of Data (1974-1981). HHS Pub. FDA 84-8229, 1984.
27. AAPM Report No, 29, Equipment Requirements and Quality Control for Mammography, AAPM 1990.
28. American National Standards Institute, Method for the Sensitometry of Medical X-ray Screen-Film Processing Systems, ANSI PH2.43-1982, New York.

5.3 AAPM Report Series

- No. 4 "Basic Quality Control in Diagnostic Radiology," AAPM Task Force on Quality Assurance Protocol (1977)
- No. 6 "Scintillation Camera Acceptance Testing & Performance Evaluation," AAPM Nuclear Medicine Committee (1980)
- No. 7 "Protocol for Neutron Beam Dosimetry," AAPM Task Group # 18 (1980)
- No. 8 "Pulse Echo Ultrasound Imaging Systems: Performance Tests & Criteria," P. Carson & J. Zagzebski (1980)
- No. 9 "Computer-Aided Scintillation Camera Acceptance Testing," AAPM Task Group of the Nuclear Medicine Committee (1982)
- No. 10 "A Standard Format for Digital Image Exchange," Baxter et al. (1982)
- No. 11 "A Guide to the Teaching of Clinical Radiological Physics to Residents in Radiology," AAPM Committee on the Training of Radiologists (1982)

- No. 12 "Evaluation of Radiation Exposure Levels in Cine Cardiac Catheterization Laboratories," AAPM Cine Task Force of the Diagnostic Radiology Committee (1984)
- No. 13 "Physical Aspects of Quality Assurance in Radiation Therapy," AAPM Radiation Therapy Committee TG #24, with contribution by TG #22 (1984)
- No. 14 "Performance Specifications and Acceptance Testing- for X-Ray Generators and Automatic Exposure Control Devices," Task Group of the Diagnostic X-Ray Imaging Committee (1985)
- No. 15 "Performance Evaluation and Quality Assurance in Digital Subtraction Angiography," AAPM Digital Radiography/Fluorography Task Group (1985)
- No. 16 "Protocol for Heavy Charged-Particle Therapy Beam Dosimetry," AAPM TG #20 of the Radiation Therapy Committee (1986)
- No. 17 "The Physical Aspects of Total and Half Body Photon Irradiation," AAPM TG #29 of the Radiation Therapy Committee (1986)
- No. 18 "A Primer on Low-Level Ionizing Radiation and its Biological Effects," AAP Biological Effects Committee (1986)
- No. 19 "Neutron Measurements Around High Energy X-Ray Radiotherapy Machines," AAPM Radiation Therapy TG #27 (1987)
- No. 20 "Site Planning for Magnetic Resonance Imaging Systems," AAPM NMR TG #2 (1987)
- No. 21 "Specification of Brachytherapy Source Strength," AAPM Radiation Therapy TG #32 (1987)
- No. 22 "Rotation-Scintillation Camera Spect Acceptance Testing and Quality Control," Task Group of the Nuclear Medicine Committee (1987)
- No. 23 "Total Skin Electron Therapy: Technique and Dosimetry," AAPM Radiation Therapy TG #30 (1988)
- No. 24 "Radiotherapy Portal Imaging Quality," AAPM Radiation Therapy TG #28 (1988)
- No. 25 "Protocols for the Radiation Safety Surveys of Diagnostic Radiological Equipment," AAPM Diagnostic X-Ray Imaging Committee TG #1 (1988)
- No. 26 "Performance Evaluation of Hyperthermia Equipment," AAPM Hyperthermia TG #1 (1989)
- No. 27 "Hyperthermia Treatment Planning," AAPM Hyperthermia Committee TG #2 (1989)
- No. 28 "Quality Assurance Methods and Phantoms for Magnetic Resonance Imaging," AAPM Nuclear-Magnetic Resonance Committee TG #1 (1990)
- No. 29 "Equipment Requirements and Quality Control for Mammography," AAPM Diagnostic X-Ray Imaging Committee TG #7 (1990)
- No. 30 "E-mail and Academic: Computer Networks," AAPM Computer Committee TG #1 (1990)
- No. 31 "Standardized Methods for Measuring Diagnostic X-Ray Exposures," AAPM Diagnostic X-Ray Imaging Committee TG # 8 (1991)

5.4 Medical Physics Reprint

"A Protocol for the Determination of Absorbed Dose from High-Energy Photon and Electron Beams," TG #21, Rad. Therapy Committee (Dec. 1983)

**Fluke Biomedical
Radiation Management Services**

6045 Cochran Road
Cleveland, Ohio 44139
440.498.2564

www.flukebiomedical.com/rms